

HC30-15: Thermostat and power change controller for electrical underfloor heating.

- Manual on/off thermostat with 3 sensor settings and temperature limit for wooden floors.
- Power change controller for pre-setting heating function for certain time intervals.
The advantage of the power change controller is that it is not influenced by other heating sources but maintains a steady heating function. The temperature limit is not active in the power change controller setting.

Specification

- | | |
|---------------------------------|----------------|
| 1. Voltage/frequency : | 230 V/50-60 Hz |
| 2. Load : | ≤16 A |
| 3. Tolerance : | ±1 °C |
| 4. Temperature regulation span: | 10 °C~ 50 °C |
| 5. Surrounding temperature: | 0 °C~+ 50 °C |

Safety

- Remember to disconnect the thermostat from the mains prior to installation and service.
- Read the instructions prior to installation.
- Must be connected by an authorised electrician.
- Must be connected in accordance with national regulations.

Design and measurements

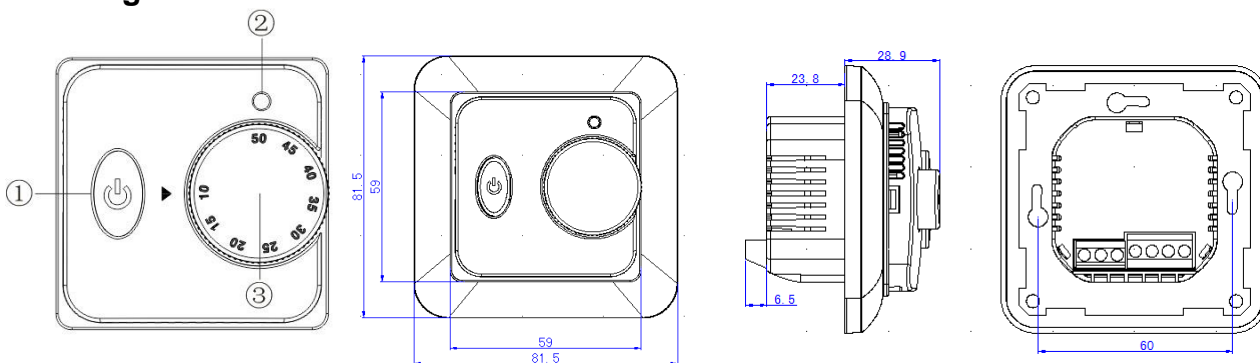

Diagram and connection

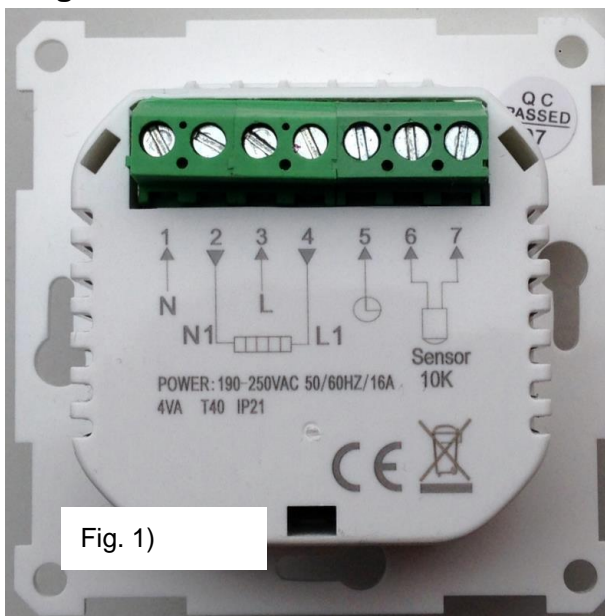

Fig. 1)

Fig. 1) Back of the thermostat.
(When mounted on the wall, the text is upside down).

- 1) N - Connection of neutral conductor 230Vac
- 2) N1 - Connection of floor heating.
- 3) L - Connection of phase conductor 230Vac
- 4) L1 - Connection of floor heating.
- 5) External signal (phase) on terminal 5 leads to a 5 degree night reduction as long as voltage is present.
- 6) Floor sensor 10 kohm NTC
- 7) Floor sensor 10 kohm NTC

- Earth is connected to the shield in the floor heating cable, e.g. with a connecting block.
- Electronic connection must be carried out by an authorised electrician according to current regulations.

Dismantling and mounting

- Always disconnect the power in the central control panel before opening the thermostat.
- Set the knob with the clock to 10 on the dial prior to dismantling.
Place the knob in the same position during mounting.

Opening the thermostat (for access to setting of dipswitches and potentiometer)

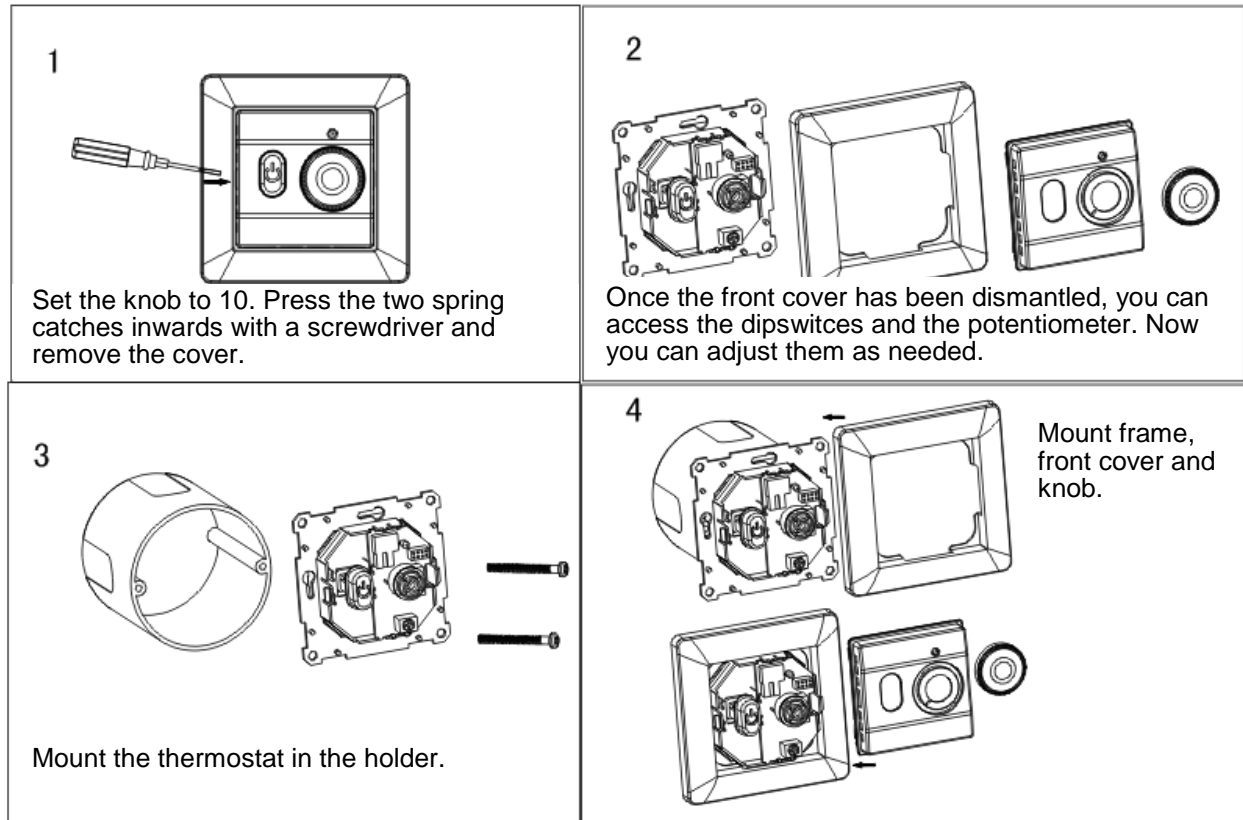

Instructions.

A. Light indicators

- Red light: The heating is on.
- Blinking red light: The floor sensor is disconnected.
Works only when the thermostat is set to floor sensor, or combined floor/room sensor.
If the red light is blinking, the heating is off.
- Green light: 5 °C night reduction/energy conservation is activated with an external «FP» signal on terminal 5. The signal must be activated for at least 20 seconds before the thermostat will react.
- Green + red light: The heating is on and 5 °C night reduction/energy conservation is activated with an external «FP» signal on terminal 5.

B. Adjustment of dipswitches

Changing the settings requires dismantling of the front.

• Adjustment of sensor. (Dipswitches RM/NC and FR/NC)

Combined floor/room sensor

Room temperature is adjusted by limiting the floor temperature.

Dipswitch RM/NC is set to RM.

Dipswitch FR/NC is set to FR or both dipswitches are set to NC.

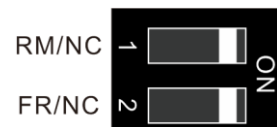
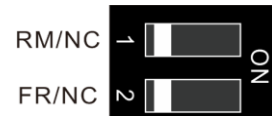

Room sensor

The room temperature is adjusted through the room sensor.

Dipswitch RM/NC is set to RM.

Dipswitch FR/NC is set to NC.

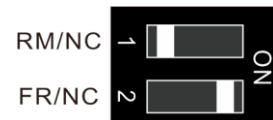

Floor sensor

The room temperature is adjusted through the floor sensor.

Dipswitch RM/NC is set to NC.

Dipswitch FR/NC is set to FR.

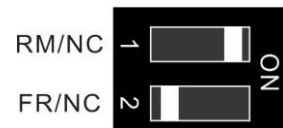

• Selection of thermostat or power change controller. (Dipswitch PI/HT)

The control must be run as power change controller.

The temperature limit is not active in this setting.

Dipswitch PI/HT is set to PI.



When the knob is set to 10, it is off. Heats 0 minutes out of 12 minutes.

When the knob is set to 50, the heating is on 80% of the time, i.e. 10 minutes out of 12 minutes.

When the knob setting is adjusted, the current 12 minute cycle finishes before the new setting is applied.

Knob set to:	On	/ Output
10	0 out of 12 min.	0%
22	3 out of 12 min.	25%
34	6 out of 12 min.	50%
42	8 out of 12 min.	67%
50	10 out of 12min.	80%

The control runs as a normal thermostat.

The temperature limit is active in this setting.

Dipswitch PI/HT is set to HT.

• **Adjustment of temperature limit. (Dipswitch LO/HI)**

Changing the settings requires dismantling of the front.

The limit is only active when “combined floor/room sensor” has been selected.

The temperature measured by the floor sensor is the reference point for the temperature limit.

Select the desired temperature limit on the potentiometer. The potentiometer is shown below. Setting to 30 degrees is shown.

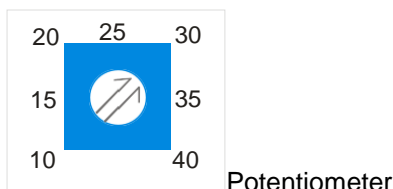

The limit is only active when the thermostat is running as a thermostat with Dipswitch setting HT (see information above).

Limit against too low temperature.

Dipswitch LO/HI is set at LO.



Limit against too high temperature.

Dipswitch LO/HI is set at HI.

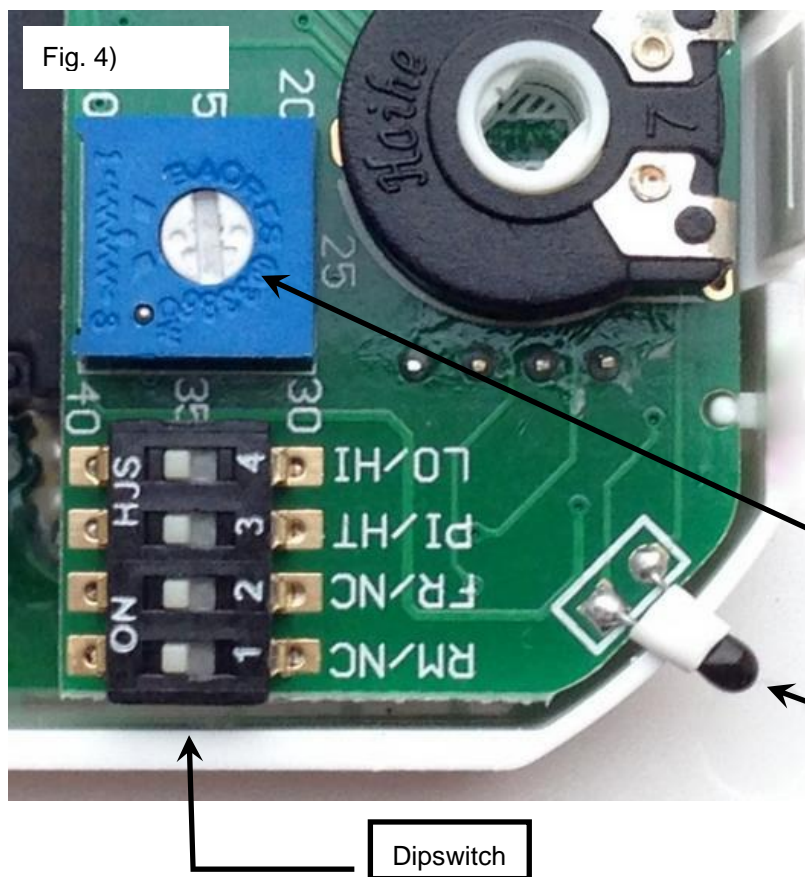

Fig. 4) The thermostat works without the front cover. Note that the text by the knuckles is upside down when the thermostat is mounted on the wall.

Shown setting with all dipswitches on the left is:

- **Combined floor/room sensor. (NC and NC)**
- **Control as a normal thermostat. (HT)**
- **Limit against too high temperature. (HI)**
The limit has been set at approximately 34 degrees on the potentiometer on the left.